

M8 MALE 90° 4 POLE / MSUD VALVE PLUG FORM A 18MM

PUR 3X0.34 black UL/CSA, drag ch 1m

Form A (18 mm)

Male M8

90°

24 V AC $\pm 20\%$ / DC $\pm 25\%$

4-pole

Z-Diode + LED

Art-No. 7005 - M8 Lite - (plastic hexagonal screw) on request

Further cable lengths on request.

Plastic housings with good resistance against chemicals and oils.

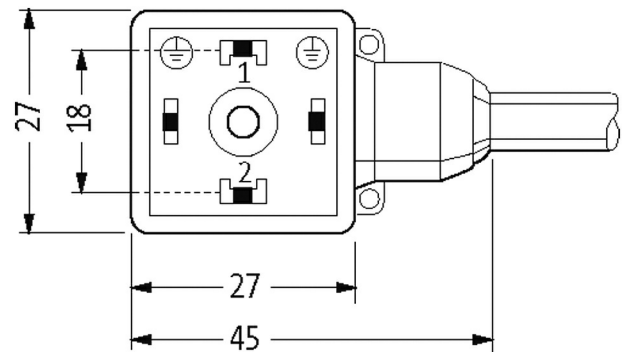
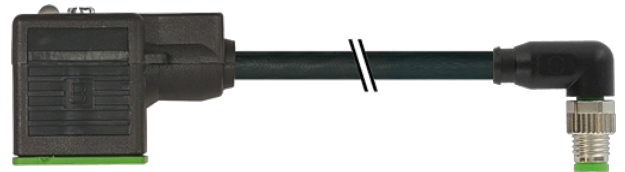
[Link to Product](#)**Illustration**

Height: 30 mm

Product may differ from Image

Approvals**Form**

Form 88731

General data

Standards DIN EN 61076-2-104 (M8)

Mounting method inserted, tightened

Material (contact) Copper alloy

Material (contact surface) MSUD (Ag); M8 (Au)

Material (gasket) PUR

| | |
|------------------------------------|--|
| Pollution Degree | 3 |
| Temperature range | -25...+85 °C, depending on cable quality |
| Cables | |
| No./diameter of wires | 3 × 0.34 mm ² |
| Wire isolation | PP (br, bl, bk) |
| C-track properties | 10 Mio. |
| Material (jacket) | PUR (UL/CSA) |
| Outer Ø | 4.1 mm ±5% |
| Bend radius (moving) | 10× outer Ø |
| Temperature range (fixed) | -40...+80 °C |
| Temperature range (mobile) | -25...+80 °C |
| Cable identification | 633 |
| Cable Type | 3 (PUR) |
| Approval (cable) | cURus (AWM-Style 20549/10493); CE conform |
| Cable weight [g/m] | 29,70 |
| Material (wire) | Cu wire, bare |
| Resistor (core) | max. 57 Ω/km (20 °C) |
| Single wire Ø (core) | 0.1 mm |
| Construction (core) | 42× 0.1 mm (multi-strand wire class 6) |
| Diameter (core) | 3 × 0.34 mm ² |
| AWG | similar to AWG 22 |
| Material (wire isolation) | PP |
| Material property (wire isolation) | CFC-, halogen-, cadmium-, silicone- and lead-free |
| Shore hardness (wire isolation) | 70 ±5 D |
| Wire-Ø incl. isolation | 1.25 mm ±5% |
| Color/numbering of wires | br, bk, bl |
| Stranding combination | 3 wires twisted |
| Shield | no |
| Material (jacket) | PUR |
| Material property (jacket) | CFC-, halogen-, cadmium-, silicone- and lead-free, matt, low-adhesion, machine easy to process, abrasion-resistant, hydrolysis and microbial resistant |
| Shore hardness (jacket) | 90 ±5 A |
| Outer-Ø (jacket) | 4.1 mm ±5% |
| Color (jacket) | black |
| chemical resistance | good resistance to oil, gasoline and chemicals (EN 60811-404) |
| thermal resistance | flame retardant UL 1581 VW1 / CSA FT1 / IEC 60332-1, IEC 60332-2-2 |
| Nominal voltage | 300 V AC |
| Test voltage | 2500 V AC |
| Current load capacity | to DIN VDE 0298-4 |
| Temperature range (fixed) | -40...+80 °C, (+90 °C at max. 10 000 operating hours) |
| Temperature range (mobile) | -25...+80 °C, (+90 °C at max. 10 000 operating hours) |
| Bend radius (fixed) | 5× outer Ø |
| Bend radius (moving) | 10× outer Ø |
| No. of bending cycles (C-track) | max. 10 Mio. (25 °C) |
| Travel speed (C-track) | max. 3 m/s |
| Acceleration (C-track) | max. 10 m/s ² |
| Torsion stress | ±180°/m |
| No. of torsion cycles | max. 2 Mio. (25 °C) |
| Torsion speed | 35 cycles/min |

Jacket Color black

Technical Data

| | |
|--|--|
| Operating voltage | 24 V AC \pm 20% / DC \pm 25% |
| Rated surge voltage | 0.8 kV |
| Operating current per contact | max. 4 A |
| No. of poles | 4 |
| Current consumption | 15 mA |
| Material group | IEC 60664-1, category I |
| Switch off peak | max. 55 V |
| LED display | yellow |
| Locking of ports | M3/M8 (recommended torque 0.4 Nm) |
| Compression gland | M8 (SW9) |
| Protection | IP65 and IP67 when plugged and screwed down (EN 60529) |
| Material | MSUD (PBT); M8 (PUR) |
| Locking material | Zinc die casting, matte nickel plated |
| Housing | Black plastic (gray on request) |
| suitable for corrugated tube (internal \varnothing) | 6.5 mm |
| Additional suppressor | Diode/Z-Diode |

Commercial data

| | |
|-----------------------|---------------|
| country of origin | CZ |
| customs tariff number | 85444290 |
| EAN | 4048879117685 |
| eClass | 27279218 |
| Packaging unit | 1 |

Sketch

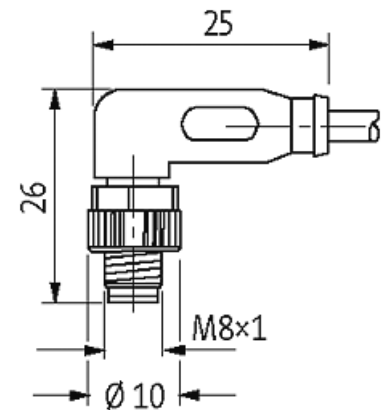

Product may differ from Image